



PREDATOR
BATTERIES LTD



PR12-200-LiFe-4S **12.8V** **200 AH**

Rechargeable Lithium Iron Phosphate Battery
UP- LiFePO4 Series Connection Range

BATTERY FEATURES

- Super safe lithium iron phosphate (LiFePO4) chemistry reducing the risk of explosion or combustion due to high impact, over-charging or short circuit situation
- Battery Management System (BMS) controls the parameters of the battery to provide optimum safety by protecting against over-charging and over-discharging
- BMS enhanced design balances the battery cells, optimizing battery performance
- Higher capacity or voltage capability through parallel or serial connections
- Delivers twice the power of lead acid batteries, even at high discharge rates, while maintaining constant power
- Faster charging and lower self-discharge
- Up to 10 times more cycles than lead acid batteries
- Compact and only 40% of the weight of comparable lead acid batteries
- Rugged impact resistant ABS case

APPROVALS

- IEC 62133 cell certificate
- UN 38.3 certified
- ISO9001:2015 - Quality management systems



DIMENSIONS:

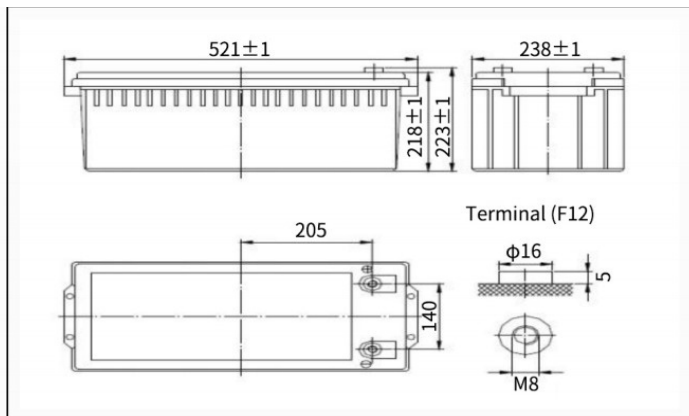

INTELLIGENT BATTERY MANAGEMENT SYSTEM

The Predator LiFe Power Series comes with an intelligent battery management system which monitors current and voltages during charge and discharge. This protects the battery from over-charge and over-discharge.

The BMS embeds smart balancing algorithms that control all cell voltages in the battery, making sure they are constantly at the same voltage level, optimizing battery capacity.

SERIAL CONNECTION CAPABLE

The Predator LiFe Power Series allows for up to 4 batteries connected in series or 4 in parallel, but not concurrently. The batteries must all be matched at voltage levels, capacity, state of charge, date of manufacturing, and chemistry.

APPLICATIONS

- Vehicle Conversion
- Solar
- Wind
- Marine Data
- Center
- Electric Propulsion
- Sports & Recreation
- Utility

PERFORMANCE SPECIFICATIONS

Nominal Voltage	12.8 V
Rated Capacity	200 AH at a Constant Current of 0.2C to 10V
Stored Energy	2560 Wh
Cycle Life (@DOD100%)	2000 Cycles
Approximate Weight	47.3 lbs (21.5 kg)
Internal Resistance	≤ 30.0 m Ω
Max Charge Current	200 A
Max Discharge Current Charging	200 A
Voltage	14.6 V
Recommended Discharge Cut-Off Voltage	10V
Series & Parallel Connection	4 in series or 4 in parallel
Operating Temperature Range	
Charge	32°F (0°C) to 113°F (45°C)
Discharge	-4°F (-20°C) to 140°F (60°C)
Recommended	59°F (15°C) to 95°F (35°C)
Self-Discharge Rate	$\leq 3\%$ /month
Long Term Storage	Charge every 6 months or as soon as OCV is 12.8V
Predator Chargers	Contact us for information on a suitable charge
Life Expectancy (years)	years5 at one cycle per day
Short Circuit Protection	Automatically recover after removal of short
Dimensional Tolerances Terminal	+/- 0.04 in. (+/- 1mm) for length and width +/- 0.08 in. (+/- 2mm) for height dimensions
Type	F12

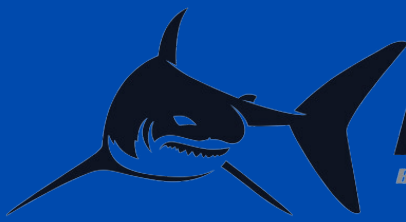

PREDATOR
BATTERIES LTD

PR12-200-LiFe-4S 12.8V 200 AH

Rechargeable Lithium Iron Phosphate Battery
UP – LiFePO4 Series Connection Range

BENEFITS OF LITHIUM

Lithium offers several performance benefits versus its sealed lead acid (SLA) equivalent. A lithium battery's capacity is independent from the discharge rate and provides constant power throughout its discharge. The degradation of a lithium battery at a high temperature is significantly reduced in comparison to SLA.

Lithium has ten times the cycle life as SLA at room temperature. Even at an elevated temperature, lithium still has increased cycle life over SLA at room temperature.

Lastly, Lithium charging follows a similar charging profile as SLA, Constant Current Constant Voltage (CC/CV). However, lithium can be charged faster, without the need for a maintenance float charge.

CAPACITY OF LiFePO4 vs. LEAD ACID AT VARIOUS CURRENTS OF DISCHARGE

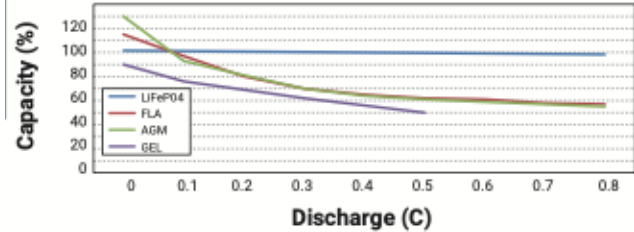

DISCHARGE VOLTAGE PROFILES AT VARIOUS RATES 25°C AMBIENT TEMPERATURE

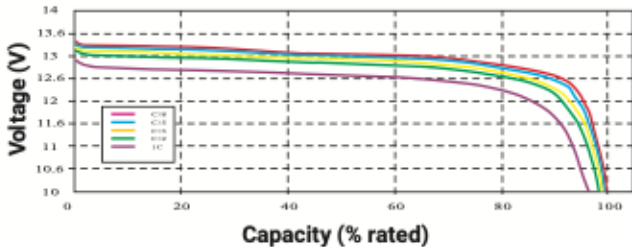

DISCHARGE VOLTAGE PROFILES AT 0.5C DISCHARGE RATE VARIOUS AMBIENT TEMPERATURES

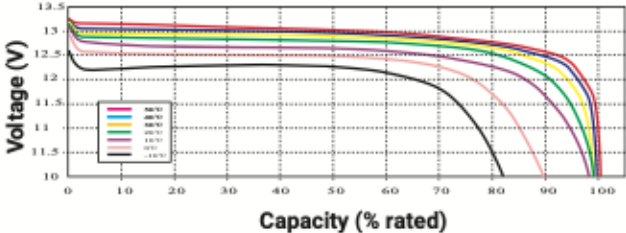

CYCLE LIFE vs. VARIOUS TEMPERATURE 0.2C CHARGE/0.5C DISCHARGE @ 100% DOD

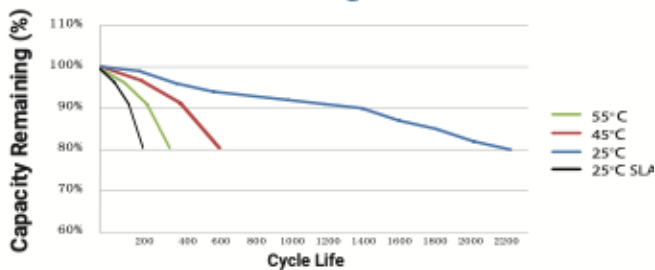

CHARGING CHARACTERISTICS (0.2C AMP @ 25°C)

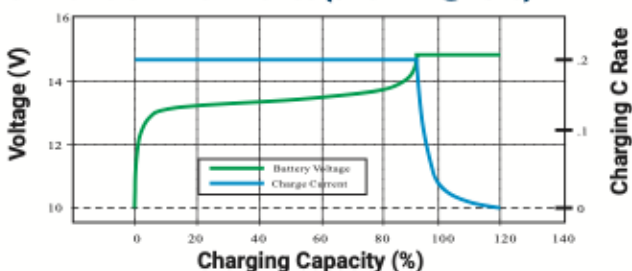

BMS TECHNICAL SPECIFICATIONS

Over charge

Over-charge protection for each cell	3.90 V
Over-charge release for each cell	3.60 V
Over-charge release method	Protection releases when all cell voltages drop below the over-charge release voltage

Over discharge

Over-discharge protection for each cell	2.00 V
Over-discharge release for each cell	2.50 V
Over-discharge release method	Protection releases when all cell voltages rise above the over-discharge release voltage

Over current

Discharge over-current protection	550-600 A
Protection delay time	31 ms
Over-current release method	Remove load for the over-current protection to release

Battery temperature

Over-temperature protection	65° C
Release temperature	55° C

Short circuit protection

Function condition	External short circuit
Short circuit delay time	250-500 ms
Release condition	Remove load for the short circuit protection to release